

# EzView™ 3-1

from Faria Performance Instruments



Part No.	Main Gauge	Second	Third
GT0008	3000 RPM Tach with Mag P.U.	Voltmeter	Fuel level
GT0016	3000 RPM Tach with Alt. P.U.	Water Temp.	Oil Press.
GT0025	4000 RPM Tach with Mag P.U.	Water Temp.	Oil Press.

## Faria Bus Gauges

The easy to read analog pointers are driven using a digital stepper motor technology for accuracy.

Driven by J1939 Faria® CAN InfoCenter via proprietary Faria® bus.

Any data carried on the J1939 CAN bus can be displayed even electric motor and generator data.

Conserves panel geography. All gauges mount in standard hole sizes. (4.375")

Available with Faria® vibration resistant spin-on back clamps.

Water resistant Packard connectors used on all electrical connections.

Face of gauge is waterproof.

Custom graphics available. Available in all Faria® Standard Styles



Actual Size  
Approx. - 4 5/8"

with quick,  
**Twist and Go™**  
technology...

**Easy Installation!**

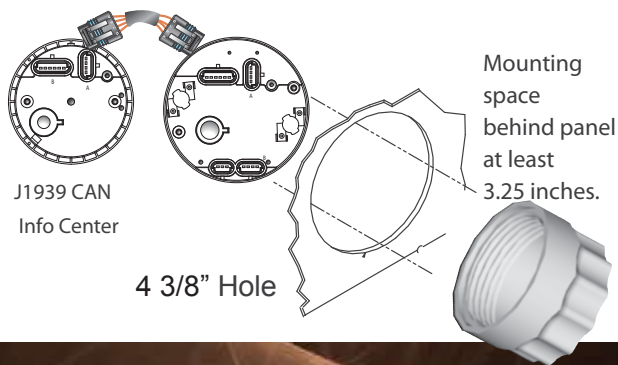
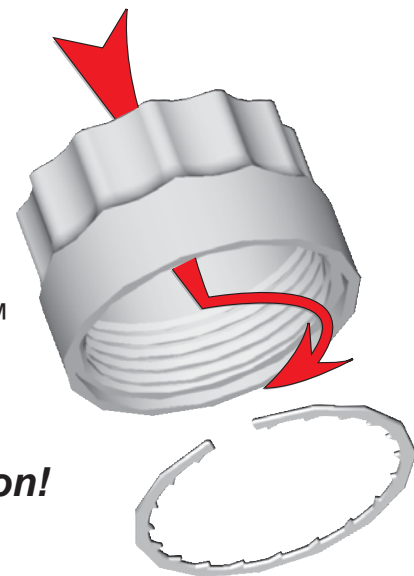

All Faria Performance Instruments comes with a Limited Lifetime Warranty see [www.faria-instruments.com](http://www.faria-instruments.com) for details.



P.O. Box 983 • Uncasville, CT 06382 Tel: 860-848-9271 Fax: 860-848-2704

fp-001-0006 rev a 5/2008